



**SINOVO**  
Innovative fiber link the world

**4G SFP+ DWDM 80KM**

## SOSP-XX99-80D

---

### ● **Features :**

- Available in all C-Band Wavelengths on the 100GHz DWDM ITU Grid
- Temperature-Stabilized DWDM EML Transmitter
- Duplex LC Connector
- Dispersion tolerance from -500ps/nm to 1600ps/nm
- Hot-Pluggable SFP+ Footprint
- Compliant with SFF-8431 MSA
- Compliant with SFF-8432 MSA
- Operating Case Temperature Standard: 0°C to 70°C

### ● **Applications**

- 4G fiber channel
- Other Optical Links

### ● **Absolute Maximum Ratings**

**Table 1- Absolute Maximum Ratings**

Parameter	Symbol	Min.	Typical	Max.	Unit	Notes
Storage Temperature	Ts	-40	-	85	°C	
Supply Voltage	Vcc5	-0.5	-	4.0	V	
Operating Humidity	RH	-	-	+85	%	



**SINOVO**  
Innovative fiber link the world

## 4G SFP+ DWDM 80KM

### SOSP-XX99-80D

- **Recommended Operating Conditions**

Table 2- Recommended operating Conditions

Parameter	Symbol	Min.	Typical	Max.	Unit	Notes
Operating Case Temperature	Top	0	-	70	°C	
Power Supply Voltage	VCC	3.14	3.3	3.46	V	
Power Supply Current	ICC	-	-	450	mA	
Power Dissipation	PD	-		1.5	W	
Data Rate	BR	9.95		11.3	Gbps	
Transmission Distance	TD	400000		80000	m	

- **Electrical Characteristics**

Table 3- Electrical Characteristics

Transmitter						
Parameter	Symbol	Unit	Min.	Typ.	Max.	Notes
Differential Data Input swing	V <sub>in,p-p</sub>	mV <sub>pp</sub>	150	-	1200	
Input Differential impedance	Z <sub>in</sub>	Ω	85	100	115	
Tx_Disable,P_Down/RST	V <sub>IL</sub>	V	0		0.8	
	V <sub>IH</sub>	V	2.0	-	V <sub>cc</sub> +0.3	
Receiver						
Differential Data Output	V <sub>out</sub>	mV <sub>pp</sub>	350		700	
Output Differential impedance	Z <sub>in</sub>	Ω	85	100	115	
Output Rise Time,20%-80%	T <sub>r</sub>	Ps	24			
Output Fall Time,20%-80%	T <sub>f</sub>	Ps	24			
Rx_Los,Mod_NR,Interrupt	V <sub>oL</sub>	V	0		0.4	
	V <sub>oH</sub>	V	V <sub>cc</sub> -0.5		V <sub>cc</sub> +0.3	



**SINOVO**  
Innovative fiber link the world

**4G SFP+ DWDM 80KM**

## SOSP-XX99-80D

### ● Transmitter Performance :

Table 4- optical TX Characteristics

Parameter		Symbol	Min.	Typical	Max.	Unit	Notes
Tx_Fault	Normal Operation	VOL	-0.3	-	0.4	V	
	Transmitter Fault	VOH	2.4	-	Vcc	V	
	Laser Disable	VIH	2.0	-	VCC+0.3	V	
Average Launch Optical Power		Pout	0	-	+4	dBm	1
Extinction Ratio		ER	9.0	-	-	dB	2
Average Launch power of OFF TX		Poff	-	-	-30	dBm	1
Optical Wavelength		$\lambda$	1xx1-0.1	1xx1	1xx1+0.1	nm	
Dispersion penalty@9.95/10.7Gpbs		DP1	-	-	2	dB	2
Dispersion penalty@11.1/11.3Gpbs		DP2	-	-	3	dB	3
Side Mode Suppression Ratio		SMSR	35	-	-	dB	

### ● Receiver Performance :

Table 5- optical RX Characteristics

Parameter	Symbol	Min.	Typical	Max.	Unit	Notes
Receiver Sensitivity @9.95Gpbs/10.7Gpbs	PIN_SENS1	-	-	-24	dBm	2
Receiver Sensitivity @11.1Gpbs/11.3Gpbs	PIN_SENS2	-	-	-23	dBm	3
Overload	PIN_OL	-7.0	-		dBm	3
Optical Center Wavelength	$\lambda_C$	1260	-	1600	nm	



**SINOVO**  
Innovative fiber link the world

**4G SFP+ DWDM 80KM**

## SOSP-XX99-80D

Los Assert		LOSA	-36	-	-	dBm	
Los De-assert		LOSD	-	-	-25	dBm	
Los hysteresis		LOSH	0.5	-		dB	
Rx_LOS	High		2.0		Vcc+0.3	V	
	Low		0		0.8	V	

Note:

1. The optical power is launched into SMF.
2. Measured with a PRBS 231-1 test pattern @9.95Gbps.
3. Measured with a PRBS 231-1 test pattern , @11.1Gbps. BER≤10-12.

### ● Recommended Host Board Power Supply Circuit

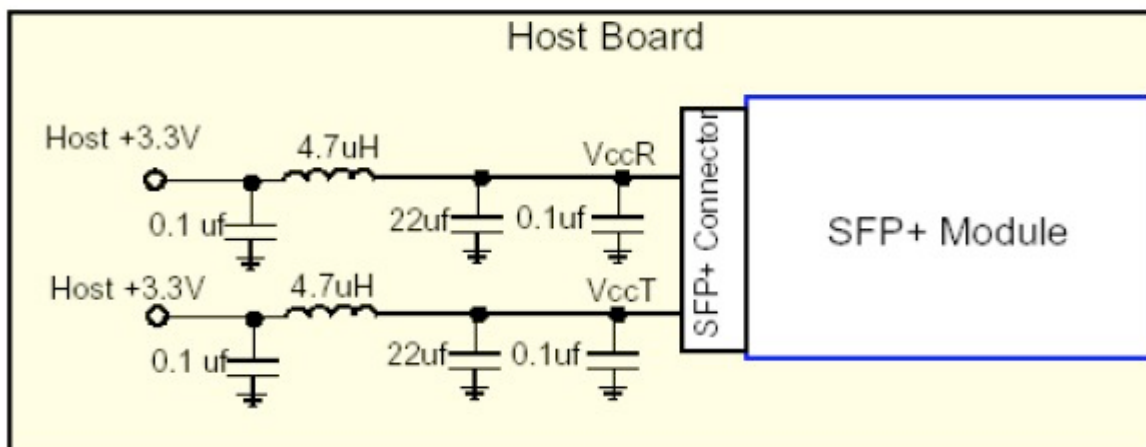

Figure 1, Recommended Host Board Power Supply Circuit



**SINOVO**  
Innovative fiber link the world

4G SFP+ DWDM 80KM

## SOSP-XX99-80D

### ● Recommended interface Circuit

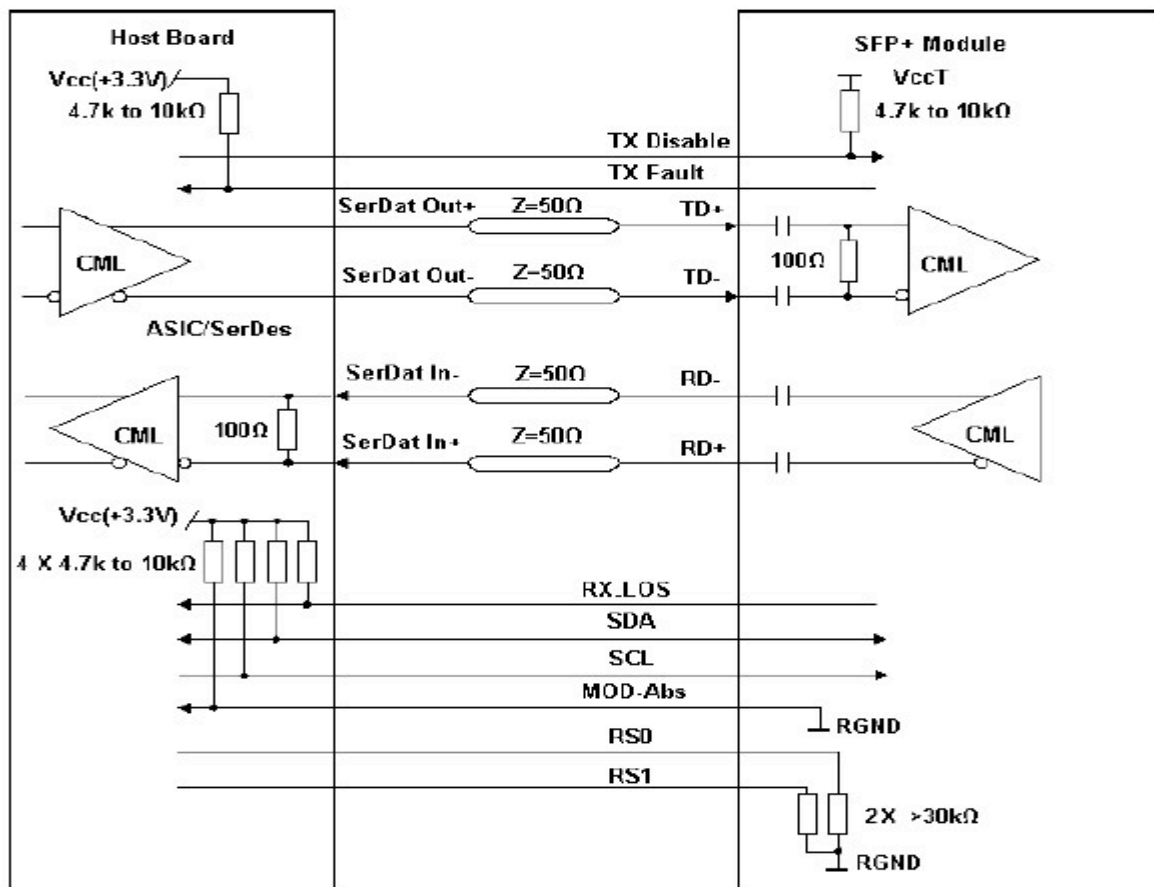

Figure 2, Recommended Interface Circuit



**SINOVO**  
Innovative fiber link the world

**4G SFP+ DWDM 80KM**

## SOSP-XX99-80D

- **Pin arrangement**

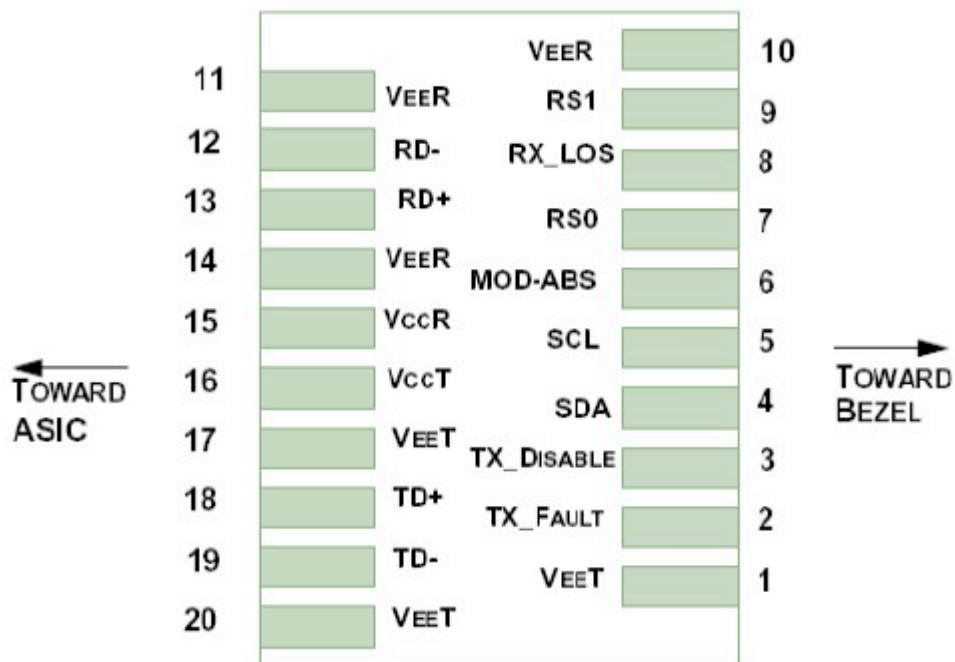

Figure 3, Pin View

Table 6-Pin Function Definitions

Pin	Name	FUNCTION	Plug Seq.	Notes
1	VeeT	Transmitter Ground	1	Note 5
2	TX Fault	Transmitter Fault Indication	3	Note 1
3	TX Disable	Transmitter Disable	3	Note 2, Module disables on high or open
4	SDA	Module Definition 2	3	2-wire Serial Interface Data Line.
5	SCL	Module Definition 1	3	2-wire Serial Interface Clock.
6	MOD_ABS	Module Definition 0	3	Note 3
7	RS0	RX Rate Select (LVTTTL).	3	Rate Select 0, optionally controls SFP+ module receiver. This pin is



**SINOVO**  
Innovative fiber link the world

## 4G SFP+ DWDM 80KM

### SOSP-XX99-80D

				pulled low to VeeT with a >30K resistor..
8	LOS	Loss of Signal	3	Note 4
9	RS1	TX Rate Select (LVTTTL).	1	Rate Select 1, optionally controls SFP+ module transmitter. This pin is pulled low to VeeT with a >30K resistor.
10	VeeR	Receiver Ground	1	Note 5
11	VeeR	Receiver Ground	1	Note 5
12	RD-	Inv. Received Data Out	3	Note 6
13	RD+	Received Data Out	3	Note 6
14	VeeR	Receiver Ground	1	Note 5
15	VccR	Receiver Power	2	3.3 ± 5%, Note 7
16	VccT	Transmitter Power	2	3.3 ± 5%, Note 7
17	VeeT	Transmitter Ground	1	Note 5
18	TD+	Transmit Data In	3	Note 8
19	TD-	Inv. Transmit Data In	3	Note 8
20	VeeT	Transmitter Ground	1	Note 5

Note:

1. TX Fault is an open collector/drain output, which should be pulled up with a 4.7K – 10KΩ resistor on the host board. Pull up voltage between 2.0V and VccT/R+0.3V. When high, output indicates a laser fault of some kind. Low indicates normal operation. In the low state, the output will be pulled to < 0.8V.
2. TX disable is an input that is used to shut down the transmitter optical output. It is pulled up within the module with a 4.7K – 10 KΩ resistor. Its states are: Low (0 – 0.8V): Transmitter on (>0.8, < 2.0V): Undefined High (2.0 – 3.465V): Transmitter Disabled Open: Transmitter Disabled
3. Module Absent, connected to VeeT or VeeR in the module.
4. LOS (Loss of Signal) is an open collector/drain output, which should be pulled up with a 4.7K – 10KΩ resistor. Pull up voltage between 2.0V and VccT/ R+0.3V. When high, this output indicates the received optical power is below the worst-case receiver sensitivity (as defined by the standard in use). Low indicates normal operation. In the low state, the output will be pulled to < 0.8V.
5. The module signal ground contacts, VeeR and VeeT, should be isolated from the module case.
6. RD-/+ : These are the differential receiver outputs. They are AC coupled 100Ω differential lines which should be terminated with 100Ω (differential) at the user SERDES. The AC coupling is done inside the module and is thus not required on the host board. The voltage swing on these lines will be between 350 and 700 mV differential (175 –350 mV single ended) when properly terminated.
7. VccR and VccT are the receiver and transmitter power supplies. They are defined as 3.3V ±5% at the SFP+ connector pin. Maximum supply current is 725mA. Recommended host board power supply filtering is shown below. Inductors with DC resistance of less than 1 ohm should be used



**SINOVO**  
Innovative fiber link the world

## 4G SFP+ DWDM 80KM

### SOSP-XX99-80D

in order to maintain the required voltage at the SFP+ input pin with 3.3V supply voltage. When the recommended supply-filtering network is used, hot plugging of the SFP+ transceiver module will result in an inrush current of no more than 30mA greater than the steady state value. VccR and VccT may be internally connected within the SFP+ transceiver module.

8. TD-/+ : These are the differential transmitter inputs. They are AC-coupled, differential lines with 100Ω differential termination inside the module. The AC coupling is done inside the module and is thus not required on the host board. The inputs will accept differential swings of 150 – 1200 mV (75 – 600mV single-ended).

#### ● Mechanical Dimension :

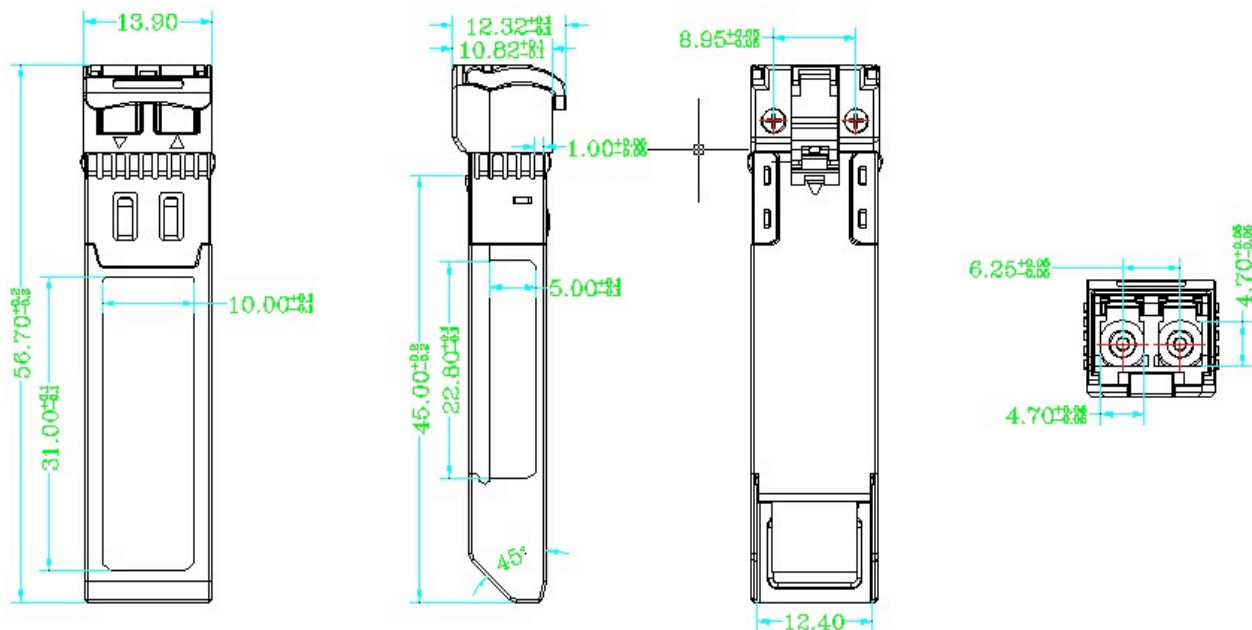

Figure 4, mechanical dimension

#### ● Order Information and Related Products :

Table 8-order information

Part Number	Product Description
SOSP-XX99-80D	SFP+ DWDM EML, 0□~70□, 80Km





**SINOVO**  
Innovative fiber link the world

## 4G SFP+ DWDM 80KM

### SOSP-XX99-80D

#### Wavelength Guide (\*\* value)

Table 7-wavelength guide

ITU channel (**)	Frequency (THz)	Wavelength (nm)	ITU Channel (**)	Frequency (THz)	Wavelength (nm)
17	191.7	1563.863	40	194.0	1545.322
18	191.8	1563.047	41	194.1	1544.526
19	191.9	1562.233	42	194.2	1543.730
20	192.0	1561.419	43	194.3	1542.936
21	192.1	1560.606	44	194.4	1542.142
22	192.2	1559.794	45	194.5	1541.349
23	192.3	1558.983	46	194.6	1540.557
24	192.4	1558.173	47	194.7	1539.766
25	192.5	1557.363	48	194.8	1538.976
26	192.6	1556.555	49	194.9	1538.186
27	192.7	1555.747	50	195.0	1537.397
28	192.8	1554.940	51	195.1	1536.609
29	192.9	1554.134	52	195.2	1535.822
30	193.0	1553.329	53	195.3	1535.036
31	193.1	1552.524	54	195.4	1534.250
32	193.2	1551.721	55	195.5	1533.465
33	193.3	1550.918	56	195.6	1532.681
34	193.4	1550.116	57	195.7	1531.898
35	193.5	1549.315	58	195.8	1531.116
36	193.6	1548.515	59	195.9	1530.334
37	193.7	1547.715	60	196.0	1529.553
38	193.8	1546.917	61	196.1	1528.773
39	193.9	1546.119			